

# STRUCTURALLY CERTIFIED

ITEM NO.	QTY	PART NUMBER	DESCRIPTION	MATERIAL / FINISH	WEIGHT
1	1	M-F7-CHS501750P-HG	SWIVELPOLE™ TOP POLE SECTION - 1750mm (68.9")	STEEL / HOT-DIP GALVANISED	7.1 kg (15.7 lb)
	1	M-F7-CHS502750P-HG	SWIVELPOLE™ TOP POLE SECTION - 2750mm (108.3")	STEEL / HOT-DIP GALVANISED	11.2 kg (24.6 lb)
	1	M-F7-CHS503750P-HG	SWIVELPOLE™ TOP POLE SECTION - 3750mm (147.6")	STEEL / HOT-DIP GALVANISED	15.3 kg (33.7 lb)
	1	M-F7-CHS504750P-HG	SWIVELPOLE™ TOP POLE SECTION - 4750mm (187.0")	STEEL / HOT-DIP GALVANISED	19.4 kg (42.7 lb)
2	1	R1-M2-5076APS-HG	MAXIS™ F7-M2 JOINT WITH ACCESS PANEL	STEEL / HOT-DIP GALVANISED	8.6 kg (18.9 lb)
3	1	F7-M2-B650860-HG	SWIVELPOLE™ BASE POLE SECTION - 860mm (33.9")	STEEL / HOT-DIP GALVANISED	9.0 kg (19.8 lb)

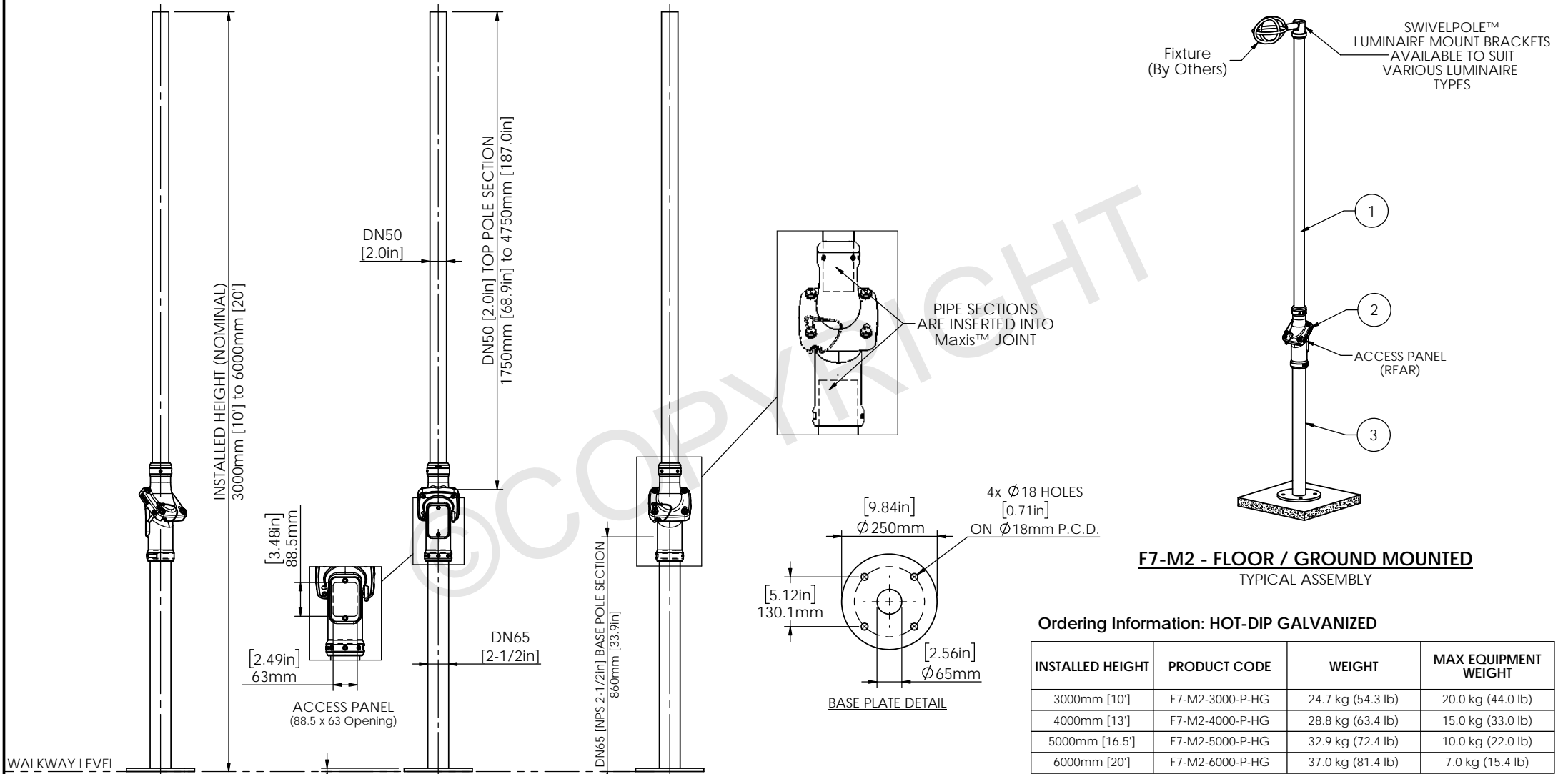

### Ordering Information: HOT-DIP GALVANIZED

INSTALLED HEIGHT	PRODUCT CODE	WEIGHT	MAX EQUIPMENT WEIGHT
3000mm [10']	F7-M2-3000-P-HG	24.7 kg (54.3 lb)	20.0 kg (44.0 lb)
4000mm [13']	F7-M2-4000-P-HG	28.8 kg (63.4 lb)	15.0 kg (33.0 lb)
5000mm [16.5']	F7-M2-5000-P-HG	32.9 kg (72.4 lb)	10.0 kg (22.0 lb)
6000mm [20']	F7-M2-6000-P-HG	37.0 kg (81.4 lb)	7.0 kg (15.4 lb)

IEC



Scan Code with QR Reader app for more Swivelpole™ Solutions

**maxis**  
PATENTED  
PRODUCTS

[www.maxisjoint.com](http://www.maxisjoint.com)

**PATENTED**  
PRODUCTS

[www.swivelpole.com](http://www.swivelpole.com)

This document is the property of and protected by copyright owned by Swivelpole Group Pty Ltd. The designs and other information embodied in this document comprise confidential information of Swivelpole Group Pty Ltd and form part of products covered by international patents and registered designs including US patent No 6957832. Unauthorised use, reproduction and disclosure are strictly prohibited. This document must not be removed from the premises of the licensed user of this document without Swivelpole Group Pty Ltd's prior approval.

ALL DIMENSIONS ARE IN MILLIMETERS

PROJECT	SERIES / CODE	PART NUMBER
SWIVELPOLE™	F	As Noted

REV 7 - 17/09/25

DRAWN BY	DATE	TITLE
BP	29/09/20	Swivelpole™ F7-Maxis™ M2
CHECKED BY	DATE	
KM	30/09/20	Base Section cw Access Panel - Top Section - PLAIN
APPROVED BY	DATE	
AI	30/09/20	General Assembly

THIRD ANGLE PROJECTION

SCALE	DRG No	REV	A3
1:10	C-IEC-F7-M2-6550-P-HG	7	A3