

ITEM NO.	QTY.	PART NUMBER	DESCRIPTION	Mass
1	1	130 x 130 CAGE BOLT - SINGLE	130 x 130 x M16 CAGE BOLT	3.75
2	8	M16NT-HG	HEX NUT M16	0.04
3	8	M16FW-HG	FLAT WASHER M16	0.02
4	4	M16SW-HG	SPRING WASHER M16	0.01

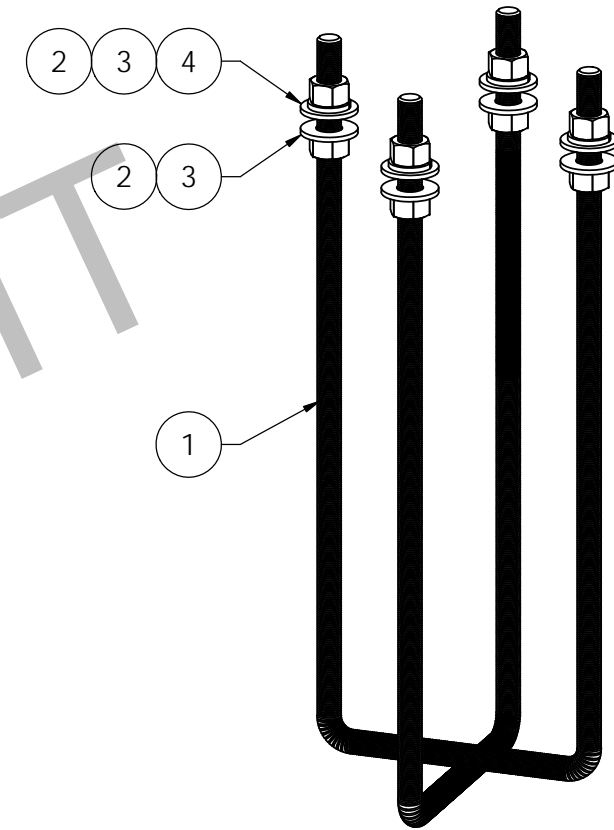

3D VIEW

PART No = CBK130-HG
MATERIAL = Steel - HDG Finish
WEIGHT = 4.2 kg

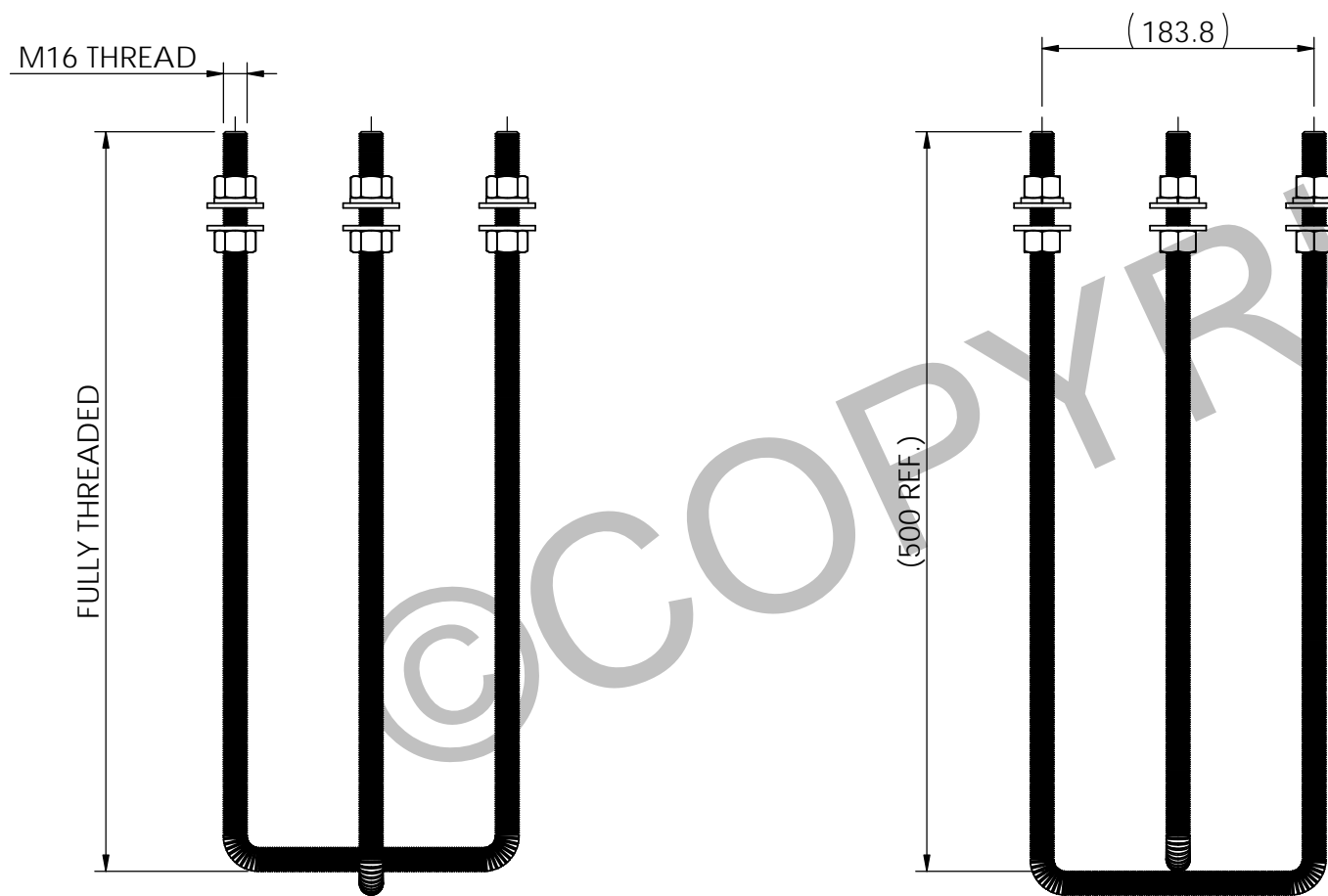
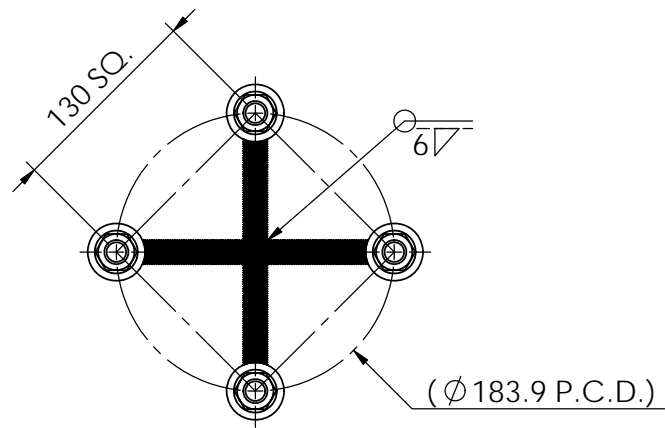

Scan Code with QR Reader app for more Swivelpole™ Solutions

maxis
PATENTED
 PRODUCTS

www.maxisjoint.com

PATENTED
 PRODUCTS

www.swivelpole.com

Swivelpole™

This document is the property of and protected by copyright owned by Swivelpole Group Pty Ltd and or Exemplar Products Pty Ltd. The designs and other information embodied in this document comprise confidential information of Swivelpole Group Pty Ltd and or Exemplar Products Pty Ltd and form part of products covered by international patents and registered designs including US patent No 6957832 and US patent No 9945143. Unauthorised use, reproduction and disclosure are strictly prohibited. This document must not be removed from the premises of the licensed user of this document without Swivelpole Group Pty Ltd's and or Exemplar Products Pty Ltd's prior approval.

ALL DIMENSIONS ARE IN MILLIMETERS		SERIES / CODE	PART NUMBER		
		MFR	CBK130-HG	(RQ1617 - 23/11/20)	
DRAWN BY	AD	DATE	26-10-09	Swivelpole™ - Maxis™ Cage Bolt Kit 130mm Crs Client Detail	
CHECKED BY	FB	DATE	16-06-10		
APPROVED BY	PP	DATE	16-06-10		
THIRD ANGLE PROJECTION		SCALE	1:5	DRG No	C-AU-CBK130-HG
				REV	2
					A3