

# FR-03 | Illuminated Wind Direction Indicator (IWDI)

## CASA compliant Illuminated (IWDI) & Non-Illuminated Wind Direction Indicators (WDI)

- CASA compliant to MOS 139 for both Illuminated and Non-Illuminated Wind Direction Indicators
- Comprising 'new generation' full Stainless Steel Top Section with sealed SS bearings
- For night operations, illumination consists of High Powered LEDs and Obstruction Beacon engineered to the standards set out in MOS 139 (9.38)
- accommodates the standard CASA Aviation Grade Size Windsock: 3650x900x225mm (length, mouth  $\varnothing$ , tail  $\varnothing$ )
- 6m Extra Heavy Duty Mid Hinged Counter Weighted Galvanised Pole - lowering eliminates any 'working at height' issues with all work at ground level
- Engineered Pole Footings Design for all Wind Regions in Australia, up to and including, Wind Region D (Cyclonic)
- Widely deployed at airports around Australia



Indicative Installation. IWDI with LEDs and Obstruction Lights mounted on fully SS Dual 900m  $\varnothing$  Windsock Frame with CASA Aviation Grade Windsock. IWDI is mounted on 6m Extra Heavy Duty Counter Weighted Galvanised Pole



IWDI installations around Australia, including retro-fit projects and elevated Hospital Helipads

# FR-03 | Illuminated Wind Direction Indicator (IWDI)

## CASA compliant Illuminated (IWDI) & Non-Illuminated Wind Direction Indicators (WDI)

- Windssocks Australia's IWDI has been custom designed and developed to be a very robust, 'fit for purpose' solution for Australian needs
- All components manufactured in Australia
- Compared to other legacy solutions, ours was designed to be easier to install, weight significantly less (approximately 50%), utilise the latest innovations in LED illumination technology
- With full Stainless Steel Construction, designed to provide years of trouble free operation
- Windssocks Australia also manufactures CASA compliant elevated HLS assemblies for Hospital Emergency and other elevated helipads - contact us for more information

Key Technical Details	F-03   900mm Ø Dual Illuminated Windsock Frame
<b>Suitable for</b>	IWDI for Aerodromes (CASA regulated and unregulated)
<b>Dimensions</b>	900mm Ø Mouth, Cross Arms (for LED Installation) ~ 1200mm long (across diameter)
<b>Maximum Windsock Size</b>	3650mm length as prescribed in CASA MOS 139
<b>Materials</b>	Frame structure – corrosion resistant 304 stainless steel Sealed Bearings 2 sets – 316 stainless steel Cross Arm Structure – for attaching illumination - corrosion resistant 304 stainless steel
<b>Weight</b>	~ 14kg (whole IWDI top section assembly, including illumination ~ 35kg)
<b>Overall height from base</b>	~ 1570mm
<b>Max Wind Rating</b>	148 km/hr (at 8m height) for Wind Region A, Cat 1.5
<b>Installation</b>	Attached via Adaptor Plate to pole top
<b>Inspection</b>	Recommended that inspection take place at least quarterly to confirm Windsock condition and performance, welds, bearings
<b>Design Life - Warranty</b>	Warranted at 5 years with a design life > 10 years with regular inspection
<b>Engineering Diagram</b>	Engineering Diagram available for the FR-03

The above table is intended as a guide only and may vary from time to time. Please confirm current specifications directly with Windssocks Australia

# FR-03 | Illuminated Wind Direction Indicator (IWDI)

## CASA compliant Illuminated (IWDI) & Non-Illuminated Wind Direction Indicators (WDI)

- FR-03 - Engineering Drawing

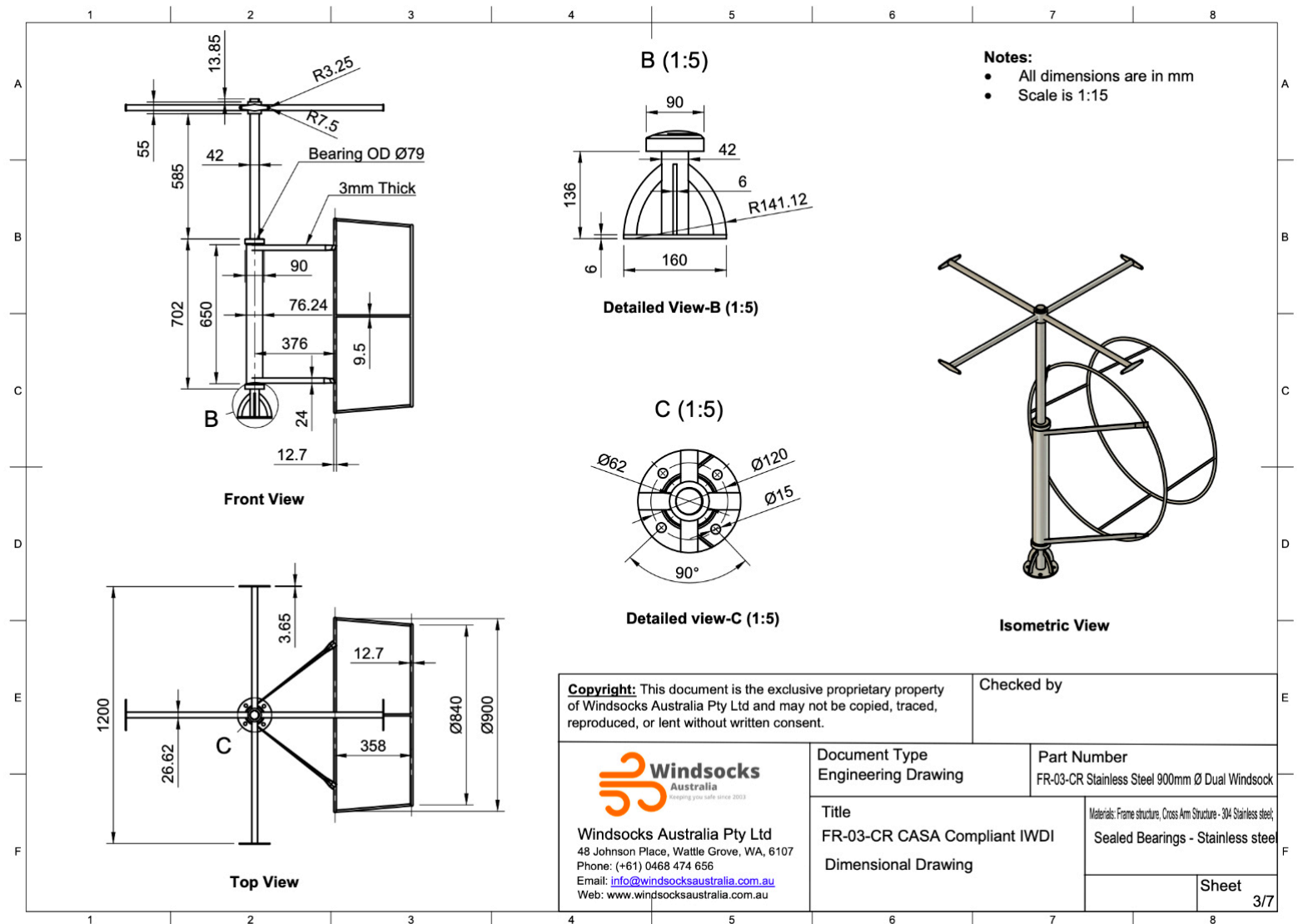

The above Drawing is intended as a guide only and may vary from time to time. Please confirm current specifications directly with Windssocks Australia

# FR-03 | Illuminated Wind Direction Indicator (IWDI)

## CASA compliant Illuminated (IWDI) & Non-Illuminated Wind Direction Indicators (WDI)

- Under CASA MOS 139, where an aerodrome is intended for night use, at least one Illuminated WDI (IWDI) is required
- Windssocks Australia IWDI's have been engineered to comply with the requirements of MOS 139 (9.38) through the use of new generation LED Flood Lights and an Obstruction Beacon
- IWDI is pre-wired for final installation at site - LED Flood Lights and Beacon on separate circuits
- Electrical compliance certificate to Australian Standards issued by Licenced Electrical Contractor

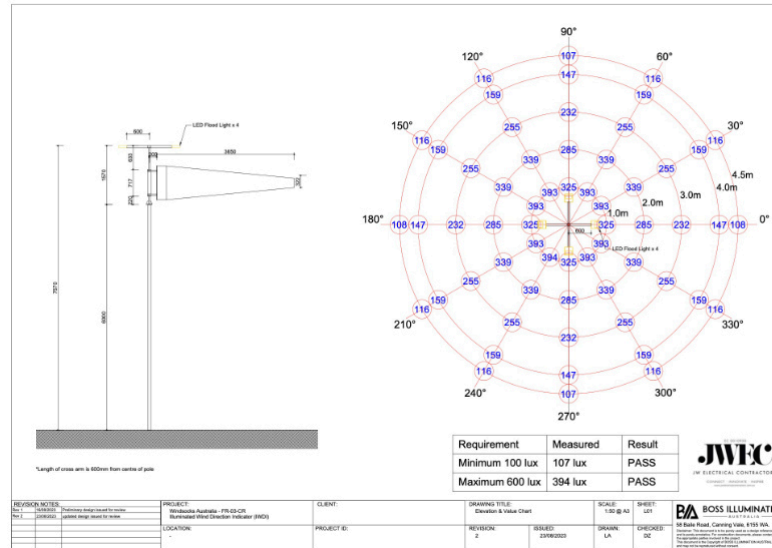

Engineered to comply with the requirements of MOS 139 (9.38) - LED lights illuminate the Windssock, ensuring at least 100 lux of bright, consistent light across the entire Windssock length and around its full 360-degree circumference. In line with AC 139.C-11: NATA test report currently underway

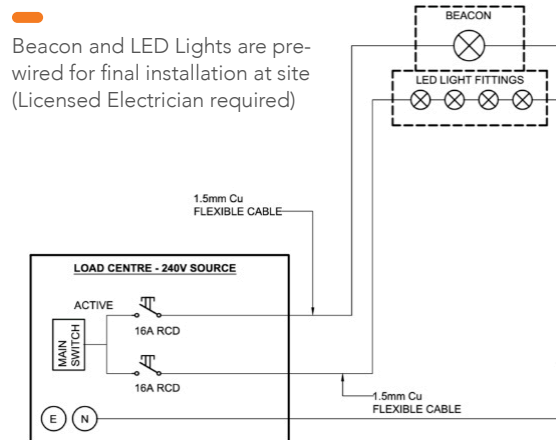

Key Technical Details	F-03   900mm Ø Dual Illuminated Windssock Frame
<b>Led Light Fittings - 4 installed</b>	For CASA MOS 139 (9.38), 50W, 240V, Castle IIIXS Flood Luminaire
<b>Beacon - Dual Light Fixtures</b>	Industry leading beacons provided through Dialight for Vigilant LED Based L-810 beacons  Designed for steady burning, this fixture is used to mark any obstacle that may present hazards to aircraft navigation  860-7R02-002 Dual Light 230V AC CASA compliant, Lower intensity Single Light available for surface level
<b>Pre-Wiring</b>	Pre-wiring pole installation cabling and testing of all wiring as per AS3000
<b>Engineering Diagram</b>	Electrical compliance certificate to Australian Standards issued by Licenced Electrical Contractor

The above table is intended as a guide only and may vary from time to time. Please confirm current specifications directly with Windssocks Australia

# FR-03 | Illuminated Wind Direction Indicator (IWDI)

## CASA compliant Illuminated (IWDI) & Non-Illuminated Wind Direction Indicators (WDI)

- MH6BHH Heavy Duty Mid Hinging Pole
- Eliminates the need and additional expense of an elevated work platform, cherry picker or safety climb system, reducing ongoing pole maintenance costs. Importantly all work is carried out at ground level.
- The IWDI can be maintained safely and effectively using the pole's simple mechanical lowering device, which can be operated by one or two people

Key Technical Details	MH6BHH Heavy Duty Mid Hinging Pole
<b>Height</b>	Typically 6m (under MOS 139), up to 10m available
<b>Weight</b>	~ 200kg (without footings)
<b>Materials</b>	Hot Dipped Galvanised Steel
<b>IWDI Fastening</b>	Mounted on galvanised flange plate – complete with chain link
<b>Mid-Hinging / Counter Weight</b>	IWDI and Pole is Counter Weighted / Balanced to allow lowering by one or two people
<b>Warranty</b>	5 years providing they have been properly installed, significantly longer design life
<b>Inspection</b>	Annual inspection recommended
<b>Pole installation</b>	Reinforced Cage with 24mm HDG Foundation Bolts, 4 X M24 @ 350PCD. Fully assembled & welded. Full pole installation documentation provided
<b>Australian Standards</b>	Mid-Hinged poles are designed to meet Australian Standards, including resultant wind actions. Independent, site specific engineering certificates available on all poles

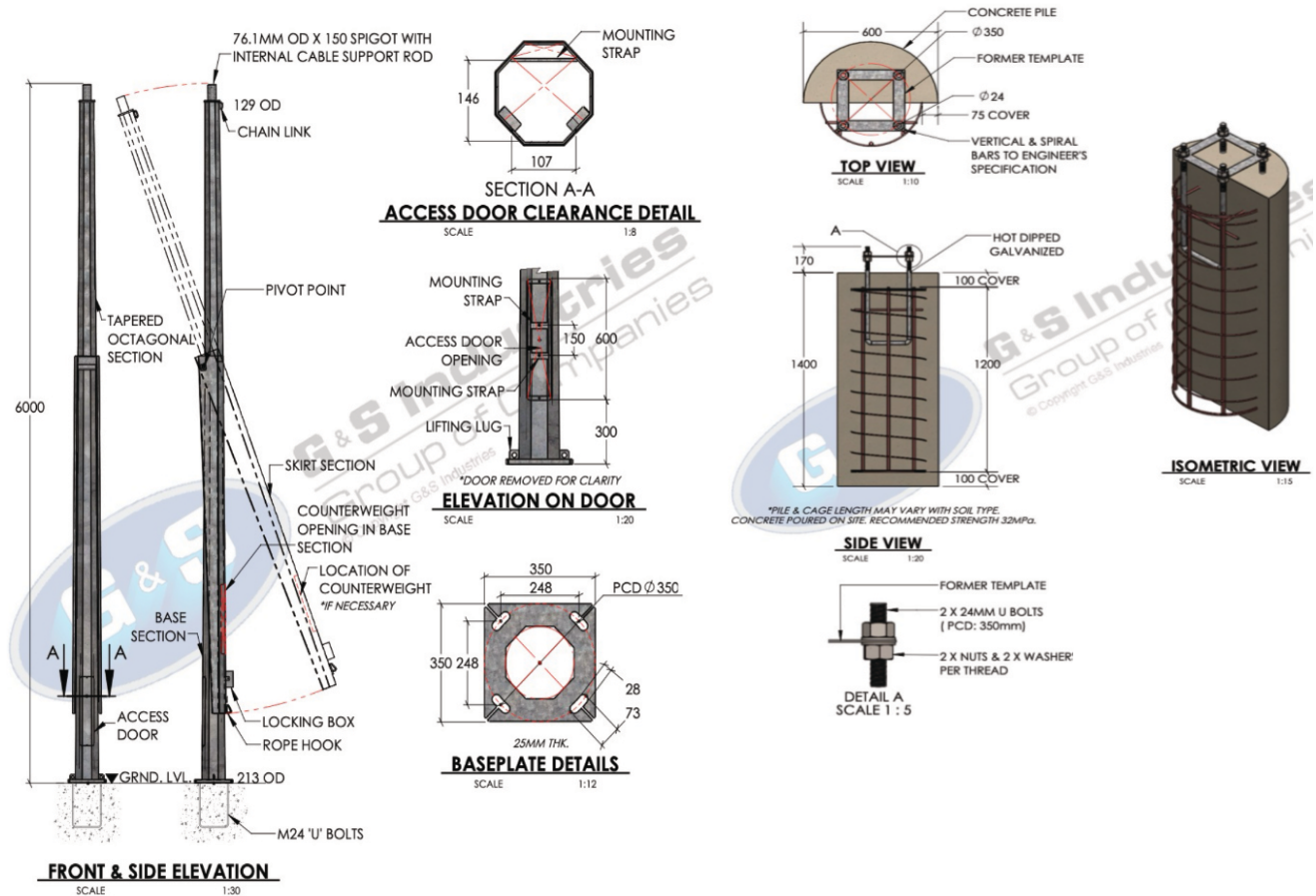

MH6BHH Extra Heavy Duty Mid Hinging Counter Balanced Pole. Footings can be Engineered up to Wind Region D (Cyclonic)

# Windsocks Australia Overview

**Our aim is to be the leading supplier of Quality Windsock solutions in Australia and the Asia Pacific region.**

Founded in 2003, Windsocks Australia is the premier specialist commercial & industrial Windsocks manufacturer in Australia. Handcrafting our products 100% in Australia using the best materials to ensure the highest quality standards.

We have delivered thousands of aviation, commercial and industrial windsock solutions throughout Australia, New Zealand, Papua New Guinea and the Asia Pacific.

**Benefit from our knowledge to assist in getting the right windsock solution for your requirements.**

**Our success is built on a reputation for:**

- High-quality products
- Extensive product knowledge
- Competitive pricing
- A commitment to innovation
- Dedication with excellent customer service
- Strong relationships with reputable manufacturers



Windsocks Australia Pty Ltd. For more info contact us on [info@windsocksaustralia.com.au](mailto:info@windsocksaustralia.com.au) or call on +61 (0) 468 474 656

[windsocksaustralia.com.au](http://windsocksaustralia.com.au)

# Windsocks Australia: Product Range

## Windsocks

We specialise in manufacturing and supplying premium windsocks designed to provide indicated wind direction and speed.

Our windsocks are made from the most durable materials and can withstand harsh weather conditions. They are available in various sizes and colours to suit different applications. Beware cheap imitations.

## Windsack Poles & Mounting Hardware

We offer a range of windsack poles and mounting hardware, including galvanised steel mid and base hinging poles, brackets, and clamps. Our products are designed for easy installation, safe operation and long-lasting performance.

## Windsack Frames & Rotor Arm Pivots

We provide high end windsack frames and Rotor Arm Pivots constructed entirely from stainless steel.

## Customisation

We understand that different industries have unique requirements. Therefore, we offer customisation services to tailor Windsack assemblies to the specific needs of our customers.



Tried and tested over many years. The highest quality Windsacks available



High end, stainless steel frames and pole adaptors, including customised fabrication



CASA compliant Illuminated Wind Direction Indicators (IWDI) used for night time operations at airports and helicopter landing sites

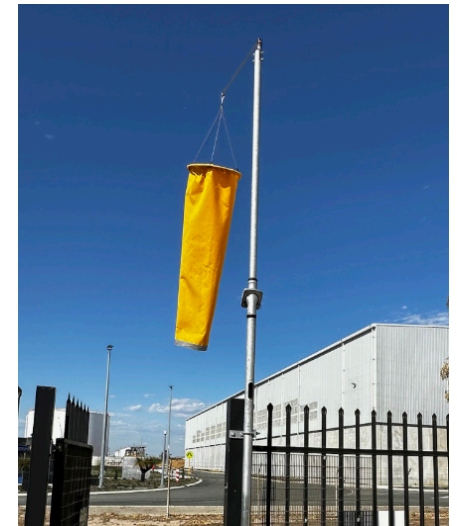

Mid and base hinging poles, providing safe and cost effective solutions - eliminating the need for elevated work platforms

# Windsocks Australia: Expertise & Industry Focus



NSW Health - retro fit HLS IWDI Windsock assembly - North Coast, NSW

**Aviation:** Our Windsocks are compliant with CASA Regulations and play a critical role in providing wind direction information for airports, helipads and airstrips, ensuring safe takeoffs and landings.



Kemerton - Lithium processing plant - Bunbury, WA

**Mining, Resources, Industrial:** We understand the unique challenges faced by these sectors. Our windsocks help improve safety during operations by providing real-time wind information in hazardous environments.

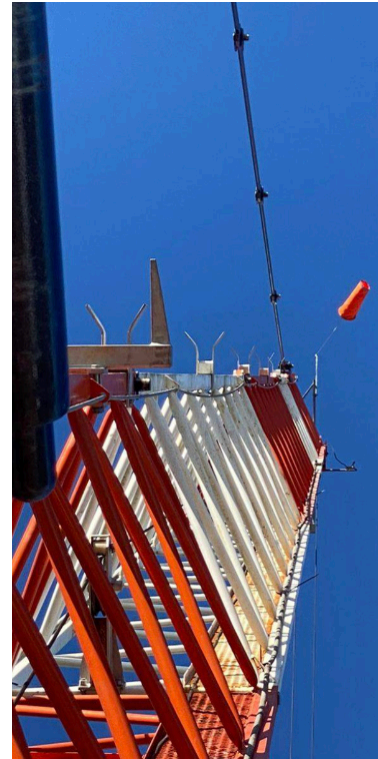

As seen on cranes around the Sydney skyline - Sydney, NSW

**Construction & Infrastructure:** Our windsocks are used on construction sites and infrastructure projects to assess wind conditions for dust control, crane operations, and other movements ensuring worker safety and optimal.



Shell Prelude - FPSO - Browse Basin - 475km north-north east of Broome, WA

**Oil and Gas:** We supply anti-static windsocks and related products to oil and gas facilities, helping to ensure safe operations and adherence to strict safety protocols.

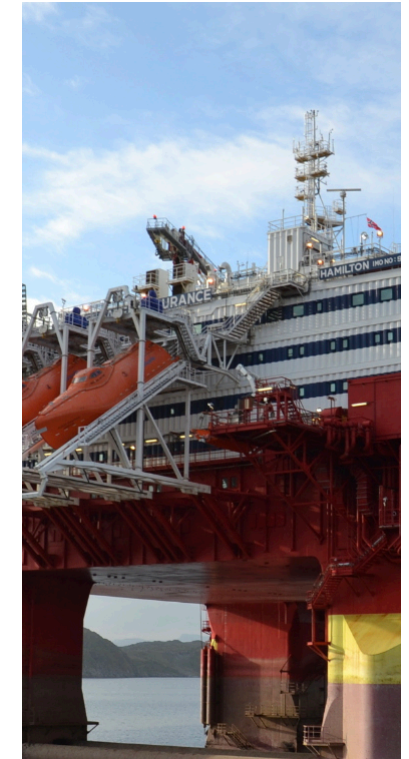

Flotel Endurance, offshore accommodation vessel - Various Locations

**Marine & Offshore:** Our windsocks are utilised in marine and offshore environments to provide wind direction guidance for vessel navigation, offshore platforms, and port operations.