

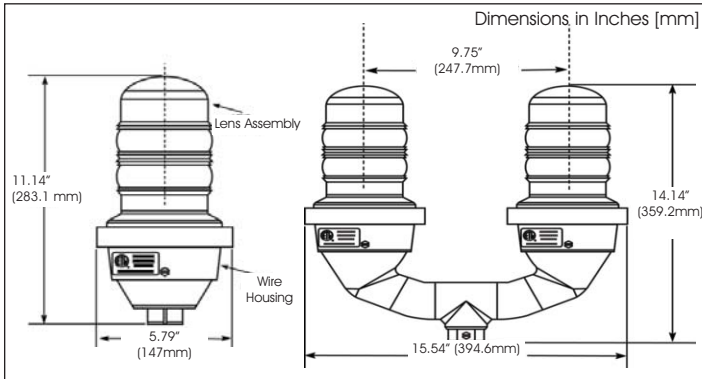

US Patent #6,425,678 (other patents pending)

## Vigilant® LED Based L-810 Low Intensity (Red) Light



### Certifications & Ratings

- FAA Approved  
(Check FAA Website for current certification)
- DGAC Mexico
- IP 66
- NEMA 4X

### Qualified By

- Intertek ETL
- Lighting Sciences Canada

### Compliant To

- ICAO Annex 14, 5th Edition, July 2009
- ICAO Aerodromes Design Manual, Chapter 18
- Canadian Aviation Regulation CAR 621 (Transport Canada)
- Nachrichten für Luffahrer Teil I Langen, 6. Januar 2005
- German Air Traffic Control Notices For Pilots Part I 6, January 2005
- CASA

### Application:

The Dialight Vigilant® L-810 is a red LED side light. Designed for steady burning, this fixture is used to mark any obstacle that may present hazards to aircraft navigation.

<b>Unit Weight:</b>	7.14 lbs (3.23 kg) (Single Unit) 16.06 lbs (7.28 kg) (Dual Unit)
<b>Wattage:</b>	15W / 120mA (120V AC Units) (+/- 10%) 16W / 120mA (230V AC Units - 60 Hz) (+/- 15%) 16W / (230V AC Units - 50 Hz) 24W / 2.0A (12V DC Units - Standard) 20W / 920mA (24V DC Units) 13W / 275mA (48V DC Units)
<b>Voltage Amp:</b>	44 VA (120V AC Units) -+10% 67 VA (230V AC Units) -+15%
<b>Operating Temp:</b>	-67°F to +131°F (-55°C to +55°C)

Part Number	Description	Voltage	Certification / Compliance
860-1R01-001	Single Light	120V AC	FAA (TC) L-810
860-1R02-001	Single Light	230V AC	FAA (TC) L-810
860-1R03-001	Single Light	12V DC	FAA (TC) L-810
860-1R04-001	Single Light	48V DC	FAA (TC) L-810
860-1R05-001	Single Light	24V DC	FAA (TC) L-810
860-1R01-002	Dual Light	120V AC	FAA (TC) L-810
860-1R02-002	Dual Light	230V AC	FAA (TC) L-810
860-1R03-002	Dual Light	12V DC	FAA (TC) L-810
860-1R04-002	Dual Light	48V DC	FAA (TC) L-810
860-1R05-002	Dual Light	24V DC	FAA (TC) L-810
860-5R02-001	Single Light	230V AC	ICAO only, 10cd
860-5R02-002	Dual Light	230V AC	ICAO only, 10cd
860-4R02-001-EU	Single Light	230V AC	ICAO only, 50cd
860-4R02-002-EU	Dual Light	230V AC	ICAO only, 50cd
860-1R02-001-EU	Single Light	230V AC	ICAO only, 32cd
860-1R02-002-EU	Dual Light	230V AC	ICAO only, 32cd
860-6R01-001	Single Light	120V AC	TC only L-810
860-6R01-002	Dual Light	120V AC	TC only L-810
860-7R02-002	Dual Light	230V AC	CASA only, 100cd

<sup>1</sup> All candela's are minimums  
See [www.dialight.com](http://www.dialight.com) for more information

Dialight also offers these LED obstruction lights for use in Hazardous Locations (Class I, Div. 2)



SafeSite® L-810 Red LED  
Side Light



SafeSite® L-810 LED  
Steady Burn Visual Signals



SafeSite® FLS Flashing  
Visual Signals