

POINT HELIPORT BEACON PHB LED IDENTIFICATION BEACON

The PHB LED medium intensity identification beacon is specified to mark the heliport or airport location. All castings are aluminum, all hardware is stainless steel and the lens is glass. There is no plastic. All exterior metal beacon parts are powdercoat painted aviation yellow for corrosion resistance that meets the US Military Standard Salt Fog Test conducted per MIL-STD-810F, Method 509.4, Procedure I.

ETL Listed to UL 1598 & UL 1598A Marine Vessels & IP66
ETL Listed to CSA C22.2 No.250.0-04 Canada
ETL Verified FAA L-864 to FAA Advisory Circular 150/5345-43G
Registered ISO 9001:2015
FAA Advisory Circular 150/5390-2B, para. 210.f, 310.h, 410.f.
ICAO Annex 14 Heliports, Volume II, para. 5.3.2. 1 to 5
ICAO Annex 14 Aerodromes, Volume I, para. 5.3.3.8 to 14
Army TM 5-811-5, para. 7-5.b. Station Identification
Class I, Division 2, Groups A B C D, T5 at $\pm 55^{\circ}$ C (option -EX)
Class I, Zone 2, Groups IIA IIB+H2 IIC, T5 at $\pm 55^{\circ}$ C (option -EX)
American Bureau of Shipping (ABS) Type Approved Product

FEATURES

- Over voltage & over current protection
- Short circuit & open circuit protection
- Metal oxide varistor surge protection
- No external plastic parts
- Factory sealed

PHB-37002-WGY-1-H



Intensity:	2,000 candelas option -H 2,500 candelas option -M
Wattage:	51.1 watts Peak (AC) option -H & -HA 30.0 watts Average (AC) option -H 38.0 watts Average (AC) option -HA 65.6 watts Peak (AC) option -M 36.0 watts Average (AC) option -M & -MA
Volt-Amps:	104 VA (AC) option -M
Input Range:	96 to 264 volts AC 10.8 to 26.4 volts DC
Temp Rating:	$\pm 55^{\circ}$ C
Dimensions: Inches (mm)	12.1 (306) x 12.1 (306) x 9.8 (249) H
Weight::	21 lbs 9.5 kg
Mounting:	4 Holes on 10.5-inch circle

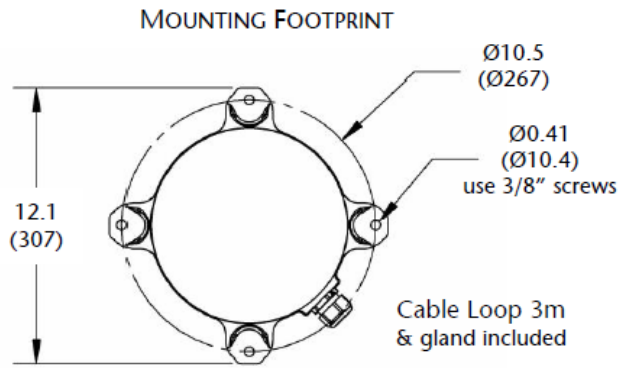

BEACON CABLE LOOP

Length: Three (3) meters
Type: SOW 600-volt
Wires: Three (3) each #14 AWG

Dimensions: Inches (mm)

**Bracket PL11215
For Wall Mounting**

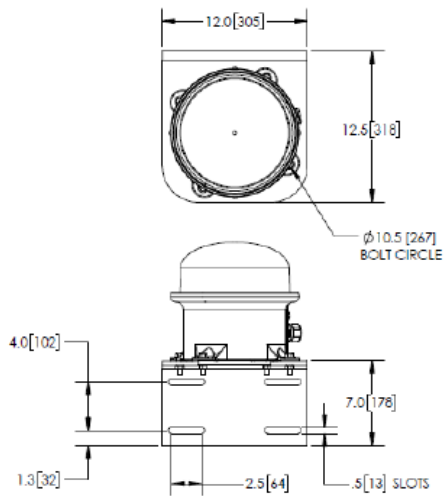

**Bracket PL11215-TPM
Tower-Pole Mounting**

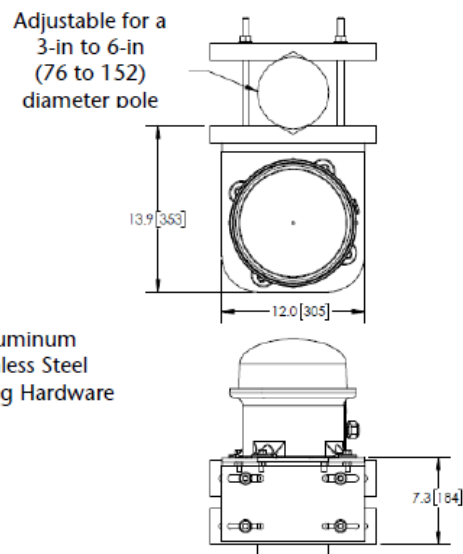

Anodized Aluminum
Includes Stainless Steel
Beacon Mounting Hardware



Airport Lighting Specialists Pty Ltd

Tel +61 3 9432 0511

Unit 5/20 Peel Street Eltham VICTORIA 3095

Sales@airportlighting.com.au

www.airportlighting.com.au