

DESIGN CRITERIA IN ACCORDANCE WITH AS1170.2:

IMPORTANCE LEVEL 1

$V_u = V_{250} = 65.2 \text{ m/s}$

$M_s = 1.0$

$M_t = 1.0$

REGION C CAT 2.5

DESIGN CRITERIA IN ACCORDANCE WITH AS1170.4:

PROBABILITY $P = 1/500$ (TABLE 3.1)

$K_p = 1.0$ (TABLE 3.1)

SITE HAZARD FACTOR Z ALLOWED = 0.09 (FIGURE 3.2(C))

GENERAL NOTES:

1. ALL REFERENCED STANDARD TO BE THE CURRENT VERSION AT THE TIME OF CONSTRUCTION.
2. MAXIMUM WIND SOCK SIZE TO BE 1500 LONG, 450 AT MOUTH & 200 AT TAIL. MAXIMUM WIND SOCK MASS = 300 GRAMS PER SQM.
3. ALL DIMENSIONS ARE IN MILLIMETERS UNLESS NOTED OTHERWISE.
4. PROVIDE SUITABLE LINER BETWEEN DISSIMILAR METALS.
5. ALL ALUMINUM TO BE GRADE 6082-T6 CONFORMING TO AS1664.1.
6. ALL STEEL WORK TO BE MIN G250 AND TO CONFORM WITH AS 4100.
7. ALL STEELWORK TO BE HOT DIP GALVANIZED.
8. ALL WELDING TO BE SHOP WELDED CONFORMING TO AS1554.1 CATEGORY SP, MINIMUM TENSILE STRENGTH 480MPa.
9. SOIL TO BE FREE OF ORGANIC MATTER AND EXCESSIVE MOISTURE.
10. SOIL IN SURROUNDING AREA TO BE COMPACTED TO 95% MDD MINIMUM.
11. CONCRETE TO BE MINIMUM N25 SUPPLIED AND LAID TO AS 3600.
12. PREPARE SITE SUCH THAT SURFACE RUNOFF CANNOT DRAIN OVER OR POND ADJACENT TO FOUNDATIONS.
13. FILL GAP BETWEEN BASEPLATE AND CONCRETE FOOTING WITH 40MPa NON-SHRINK GROUT.
14. FIX WIND SOCK TO POST AS PER MANUFACTURER'S SPECIFICATION.
15. THE DESIGN OF POLE, INCLUDING U-BOLT AND FOOTING WIND IS BASED ON THE CONDITION THAT WIND SOCK IS REMOVED WHEN WIND EXCEEDS V_u .

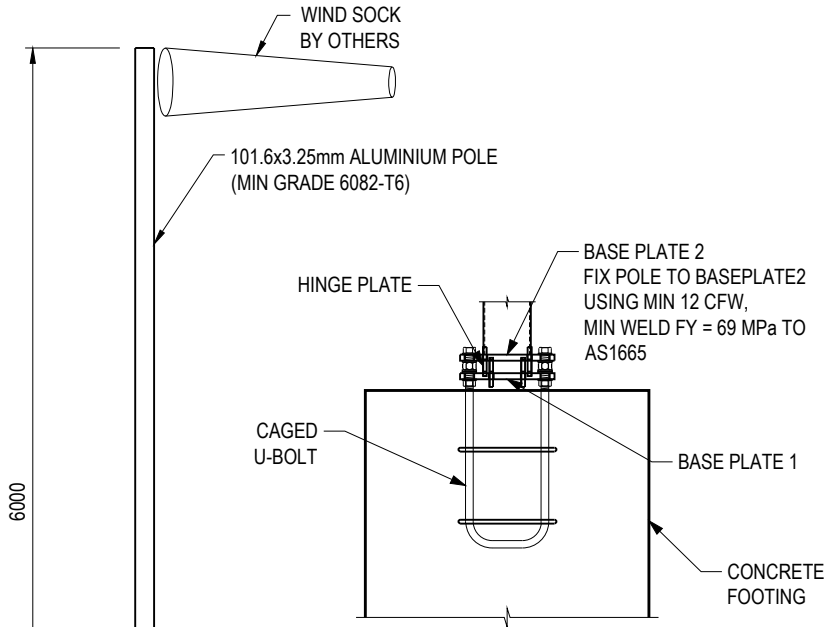

DETAIL

NTS

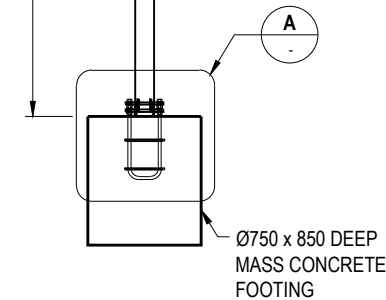
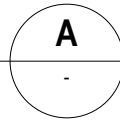

TYPICAL ELEVATION

NTS

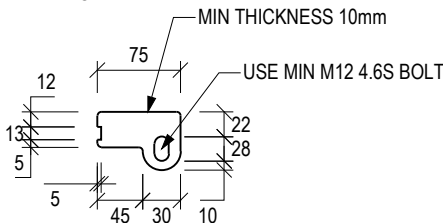

TYPE C HINGE DETAIL

NTS

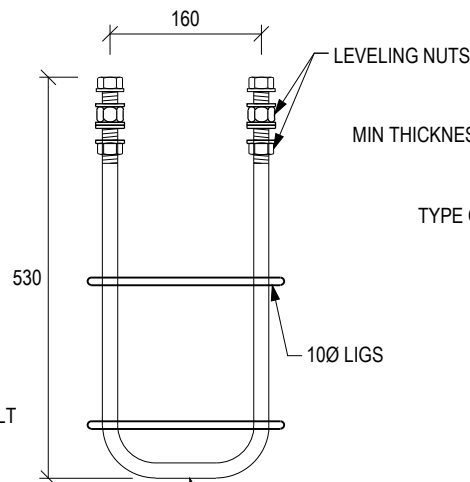

CAGED U-BOLT DETAILS

NTS

M16 4.6S GALVANIZED U-BOLT. 450 EMBEDMENT. 80mm THREAD LENGTH

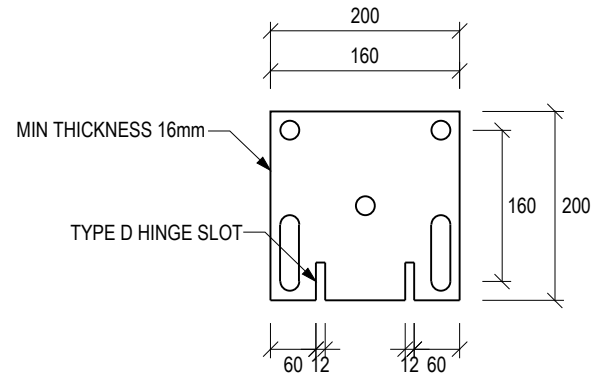

TYPE C BASEPLATE 2 DETAIL

NTS

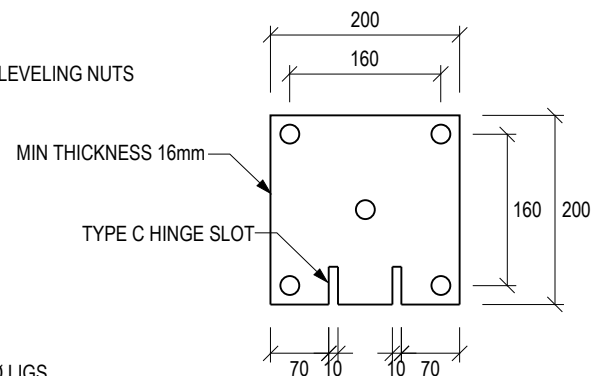

TYPE C BASEPLATE 1 DETAIL

NTS



PROMPT
ENGINEERING

Michael Young

MICHAEL YOUNG BE MIE (276533)
PLN_44986.06-09-2018

TITLE	ELEVATION, DETAILS AND SPECIFICATIONS	 PROMPT ENGINEERING <small>CIVIL STRUCTURAL GEOTECHNICAL</small>	DATE	06/07/2018	CODE: MS-52H
PROJECT	HINGING BASE AND WINDSOCK POLE		DRAWN	GERARDO PEREZ	
CLIENT	MARINDUST SALES		DESIGNED	CHANDNI PATEL	
			CHECKED	ENRICO TONGCO	
Copyright Prompt Engineering Pty. Ltd. PHONE: +61 8 6369 9400. EMAIL: support@prompteng.com.au			A4 SCALE	NTS	
			JOB REF.	PLN_44986	