

# Vigilant LED Based L-810

## Low Intensity (Red) RTO Side Light - Infrared (IR) models available

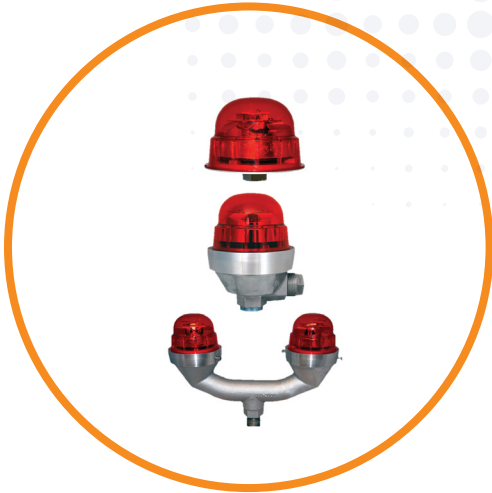

### Certifications & Compliance

- FAA AC 150 / 5345 - 43G
- FAA EB No. 67D
- IP66
- German Air Traffic Control Notices for Pilots Part I 6, January 2005
- Transport Canada CAR 621.19
- ICAO Annex 14
- DGAC Mexico
- Nachrichten für Luftfahrer Teil I Langen, 6. Januar 2005

### Features & Benefits

- ETL verified to FAA standards
- Superior surge and lightning protection
- Controllers available for all applications
- Compact, low power design
- Ideal for towers, stacks, wind turbines, buildings, etc.
- 360 degree coverage for each flash head
- Shock and vibration resistant
- Lighting kits available for standard towers

### Mechanical Information:

<b>Unit weight:</b>	1.25 lbs (0.56 kg) (Retro unit) 2.00 lbs (0.91 kg) (Single unit) 4.60 lbs (2.09 kg) (Dual unit)
<b>Supply voltage ranges:</b>	Nominal +/- 10%
<b>Power factor:</b>	> 0.9 (All AC units)
<b>Operating temperature:</b>	-40°F to +131°F (-40°F to +55°F)
<b>Input AC frequency:</b>	50/60Hz

All values typical unless otherwise stated (tolerance +/- 10%)

US Patent #7,604,384

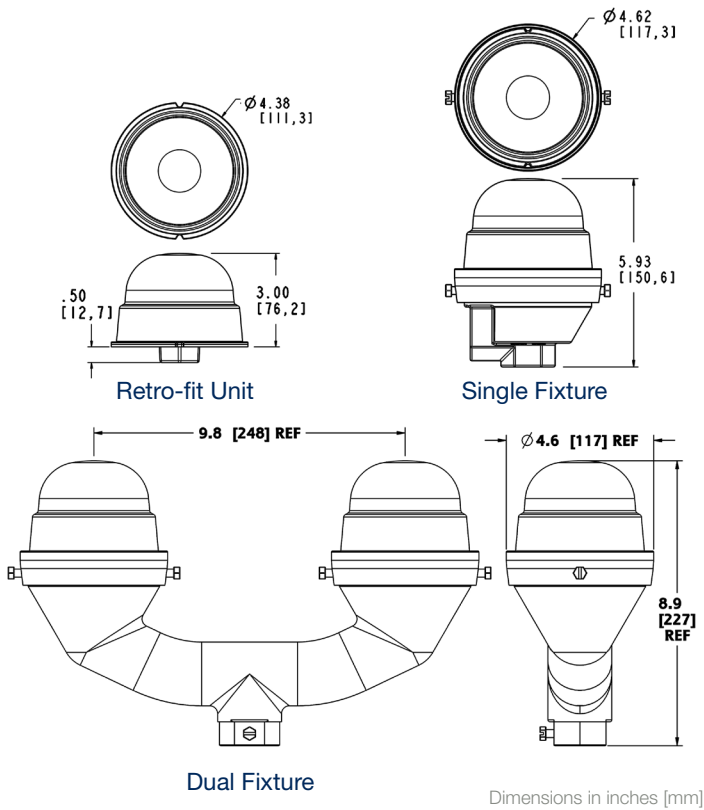

# Vigilant LED Based L-810

## Low Intensity (Red) RTO Side Light Ordering Information

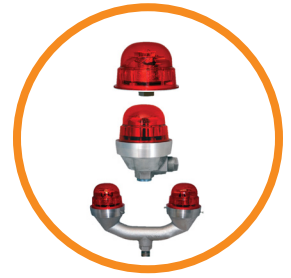

Part Number	Description	Voltage	Certification / Compliance	Wattage
RTO-1R06-001	Single Light	277V AC	FAA (TC) L-810	8.0
RTO-1R07-001	Single Light	120-240V AC	FAA (TC) L-810	6.5
RTO-1R08-001	Single Light	12-48V DC	FAA (TC) L-810	3.5
RTO-1R18-001	Single Light - Low Power	12-48V DC	FAA (TC) L-810	1.5
RTO-1R06-002	Dual Light	277V AC	FAA (TC) L-810	8.0
RTO-1R07-002	Dual Light	120-240V AC	FAA (TC) L-810	6.5
RTO-1R08-002	Dual Light	12-48V DC	FAA (TC) L-810	3.5
RTO-1R18-002	Dual Light - Low Power	12-48V DC	FAA (TC) L-810	1.5
RTO-1R06-004	Single Retro-fit Light	277V AC	FAA (TC) L-810	8.0
RTO-1R07-004	Single Retro-fit Light	120-240V AC	FAA (TC) L-810	6.5
RTO-1R08-004	Single Retro-fit Light	12-48V DC	FAA (TC) L-810	3.5
RTO-1R18-004	Single Retro-fit Light - Low Power	12-48V DC	FAA (TC) L-810	1.5
RTO-CR07-001	Single Light Red / Infrared (IR)	120-240V AC	FAA (TC) L-810	5.5
RTO-CR08-001	Single Light Red / Infrared (IR)	12-48V DC	FAA (TC) L-810	5.0
RTO-CR07-002	Dual Light Red / Infrared (IR)	120-240V AC	FAA (TC) L-810	5.5
RTO-CR08-002	Dual Light Red / Infrared (IR)	12-48V DC	FAA (TC) L-810	5.0
RTO-CR07-004	Single Retro-fit Light Red / Infrared (IR)	120-240 V AC	FAA (TC) L-810	5.5
RTO-CR08-004	Single Retro-fit Light Red / Infrared (IR)	12-48V DC	FAA (TC) L-810	5.0
RTO-1R07-001-EU	Single Light	120-240V AC	ICAO only, 32cd	6.5
RTO-1R07-002-EU	Dual Light	120-240V AC	ICAO only, 32cd	6.5
RTO-1R07-004-EU	Single Retro-fit Light	120-240V AC	ICAO only, 32cd	6.5
RTO-6CR7-001	Single Light Red / Infrared (IR)	120-240V AC	TC only L-810	9.0
RTO-6CR7-002	Dual Light Red / Infrared (IR)	120-240V AC	TC only L-810	9.0
RTO-6CR7-004	Single Retro-fit Light Red / Infrared (IR)	120-240V AC	TC only L-810	9.0