

4

3

2

1

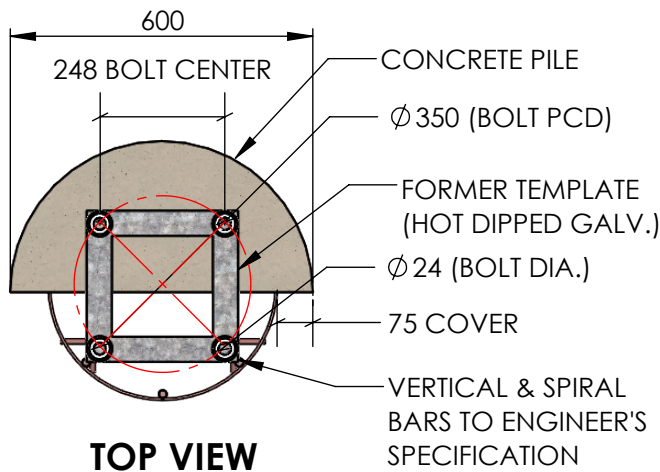

TOP VIEW
SCALE 1:10

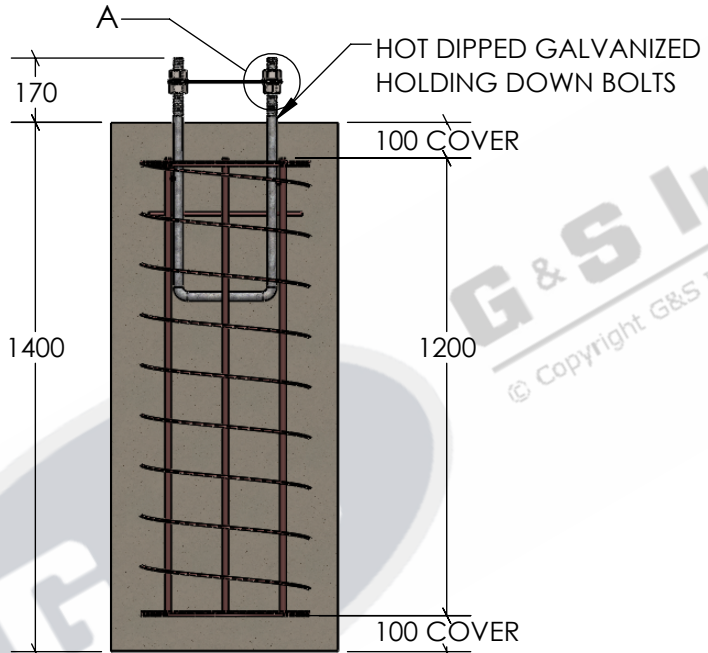

SIDE VIEW
SCALE 1:20

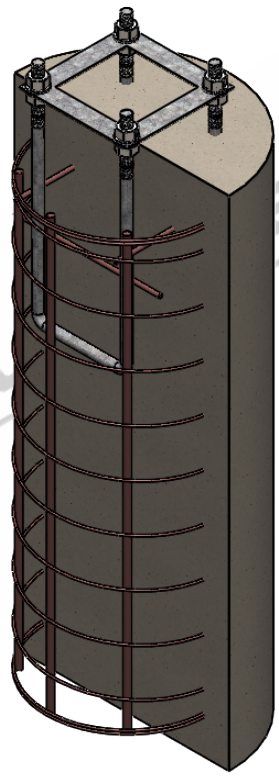

ISOMETRIC VIEW
SCALE 1:15

*PILE & CAGE LENGTH MAY VARY WITH SOIL TYPE.
CONCRETE POURED ON SITE. RECOMMENDED STRENGTH 32MPa.

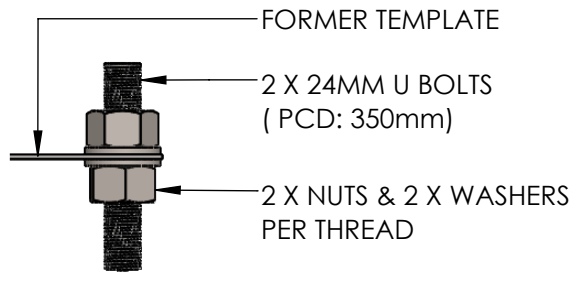

DETAIL A
SCALE 1:5

STANDARDS

- ALL PRODUCTS TO CONFORM TO THE FOLLOWING AUSTRALIAN STANDARDS.
- * AS 1170.2 Structural design actions - Wind actions.
 - * AS 1554(set) Structural steel welding set.
 - * AS 2159: Piling - Design & Installation.
 - * AS 2870: Residential slab footings - Construction.
 - * AS 3600: Concrete structures.
 - * AS 3678: Structural steel - Hot rolled plates, floorplates and slabs.
 - * AS 4680: Hot dip galvanized (Zinc) Coatings on fabricated ferrous articles.
 - * AS/NZS 4671: Steel reinforcing materials.
 - * AS/NZS 4600: Cold formed steel structures.



G & S Industries
97 GUTHRIE STREET,
OSBORNE PARK W.A. 6017
PH : +6108 9446 8044
EMAIL: sales@gsindustries.com.au
WEB: www.gsindustries.com.au

PROPRIETARY AND CONFIDENTIAL	
THE INFORMATION CONTAINED IN THIS DRAWING IS THE SOLE PROPERTY OF G&S INDUSTRIES. ANY REPRODUCTION IN PART OR AS A WHOLE WITHOUT THE WRITTEN PERMISSION OF G&S INDUSTRIES IS PROHIBITED.	
SCALE: AS SHOWN	PRODUCT WEIGHT: 34.4kg. <small>(NOT INCLUDING THE CONCRETE PILE)</small>
PRODUCT FINISH: HOT DIPPED GALVANIZED	
CUSTOMER APPROVAL:	
CUSTOMER NAME / PROJECT:	

	NAME	DATE
DRAWN	N. A.	14.10.2022
CHECKED	S. G.	14.10.2022
APPROVED	R. G.	14.10.2022
COPYRIGHT		
THIS DOCUMENT IS PRODUCED BY G&S INDUSTRIES MUST NOT BE COPIED, TRACED, REPRODUCED, OR LENT WITHOUT WRITTEN CONSENT		

PART NUMBER : CR24/4/350	
TITLE : 24MM (4 BOLT) 350 PCD CAGED RAGBOLT ASSEMBLY SUIT PILE STYLE FOOTING FULLY WELDED AND ASSEMBLED	
SIZE A4	DWG. NO. ZLRG2240
	REV. 0

4

3

2

1